

IMPACT OF LOW FREQUENCY ELECTROMAGNETIC FIELD EXPOSURE ON THE CANDIDA ALBICANS

Ivona Malíková^{*} — Ladislav Janoušek^{*} —
Vladislava Fantova^{**} — Jaroslav Jíra^{**} — Vítězslav Kříha^{**}

Effect of low frequency electromagnetic field on growth of selected microorganism is studied in the article. The diploid fungus that grows both as yeast and filamentous cell was chosen for this research. The theory of ion parametric resonance was taken as the base for studying the influence of electromagnetic field on biological structures. We tested the hypothesis, whether it is possible to observe the change in growth properties of *Candida albicans* with an AC electromagnetic field tuned to resonance with calcium ions cyclotron frequency.

Key words: biological structures, *Candida albicans*, low frequency electromagnetic field, exposure coil system, cyclotron resonance, ion parametric resonance

1 INTRODUCTION

Modern civilization can be characterized by usage of various electric devices generating local electromagnetic fields with wide range of frequencies. Many people do not realize that these appliances generate some electromagnetic radiation and that this radiation can affect their tissues. A lot of researchers focus on revealing the probable effects of electromagnetic field (EMF) created by the low frequency (LF) appliances. Some surveys are oriented to find out whether there can be some risk for biological structures, *ie* for different types of tissue, cells, blood, secretion of hormones, cell proliferation, *etc.*

Scientific Committee on Emerging and Newly Identified Health Risks updated its opinion on 21st March 2007 in the light of newly available information in order to ensure the best possible quality for the risk assessment. The section is divided into four separate sub-sections based on frequency bands. The possible health effects of intermediate frequency (IF) and extremely low frequency (ELF), from 0 to 100 kHz, were used for the purpose of the research. Previous opinion expressed its concern due to the lack of data and experiments in these frequency bands. Very rare experimental results on IF, ELF and health risks have been presented since then. Consequently, the data are limited for official risk assessment. Committee expressed the importance of research in this area [1].

This topic begins to be more relevant nowadays. The amount of sources of artificial LF EMF is increasing. However recent state of knowledge does not allow us to

describe precise mechanisms and determine significance of EMF effect on biological systems.

Investigated thruster designs, have always implemented two or more electrodes and employed mostly DC voltage. More electrodes mean more weight, so it is worth asking, whether one electrode would not be enough. The idea of generating thrust by a single electrode is not new, since a corona pinwheel can be considered a single electrode thrust generating device. However it has not been considered as a candidate aerial propulsion system yet.

The purpose of this work is to investigate linear thrust generation by a single pin emitter electrode under AC excitation, with emphasis on propulsion applications.

2 LF EMF IMPACT

2.1 Interaction between EMF and cells

Studies dealing with investigations in this branch show many possibilities to pursue in the process of quantifying and clarifying the action mechanisms. The eukaryotic cell is divided into separated compartments (cytoplasm, the nucleus, mitochondria and other organelles) by lipid bilayers cellular membranes. Cell as whole is also separated by the cellular membrane from the external environment. The compartment arrangement allows different concentration of solutes in intra-compartmental liquids. The transfer of ions through the cellular membranes is essential for the formation of electrochemical potential of the cells. This potential influences the processes in the cell and is strictly regulated. The negative potential inside the

^{*} Department of Electromagnetic and Biomedical Engineering, Faculty of Electrical Engineering, University of Žilina, Žilina, Slovakia, ivona.malikova@fel.uniza.sk; ^{**} Department of Physics, Faculty of Electrical Engineering, Czech Technical University in Prague, Prague, Czech Republic

cells in the rest state is consequence of relative deficiency of positive ions inside the cell. Calcium and magnesium ions are actively pumped from the cell, so that their concentrations are usually few orders lower in comparing to the extracellular space. Transfer of these ions into the cell causes not only electric potential, but the presence of these ions is important for initiation or suppression of biochemical reactions. Many enzymatic reactions or enzymatic cascades require the presence of calcium or magnesium ions, or both. Interaction of electromagnetic field with the cellular mechanisms to ensure proper management of these ions subsequently can affect many reactions inside the cell, [2].

2.2 Cell channels

One of the structures participating in regulation of cell activity is voltage gate of ion channels. The Ca^{2+} calcium ion is one of the principal cell ions for regulation and signal transduction. It is ubiquitous and mediates communication between cells and it also has a function of regulation. For example, if the ability of voltage calcium ion channel and the concentration of calcium in cytoplasm of vascular muscle are decreased, vasodilatation appears.

Erdal *et al* [3] studied cytogenetic effects in bone marrow cells from Wistar rats exposed to a 50 Hz, 1.0 mT magnetic field for 45 days, 4h/day. Micronucleus assay detected increase of micronuclei. Also study by Yang *et al*. [4] investigated the possible interaction between mutated genes for DNA repair enzymes and ELF EMF exposure in acute children leukaemia. An interaction between a specific mutation and presence of artificial EMF (transformer station or power lines) was noted. Many other researches claim effect in chromosomal instability in fibroblast, effects on the nervous system, development, melatonin production or increase anxiety-related behaviour [5-8].

2.3 Ion parametric resonance

In the 80s, it was observed that weak magnetic field applied to a living organism produces variations of the ion concentration inside the cells whenever the frequency of the applied field matches a characteristic frequency of the involved ion species, called the ion cyclotron frequency (ICF)

$$f_c = \frac{qB_0}{2\pi m} \quad (1)$$

where q is the ion electrical charge, m is the mass of ion and B_0 is static magnetic flux density [9].

An ion current exhibits a transient enhancement by applying a static magnetic field contemporary with an alternate magnetic field with flux density B_{ac} , with a frequency matching the cyclotron frequency f_c . Static magnetic field flux density B_0 is parallel to B_{ac} [9, 10]. Parameters for the cyclotron resonance of typical ions are shown in Tab. 1.

The paper focuses especially on the Ion Parametric Resonance (IPR) theory. The IPR model predicts that distinct patterns of field-induced biological responses will

occur at particular magnetic field combinations which establish ion resonances.

Table 1. Parameters for the cyclotron resonance

Ion	Q/m ($\mu\text{C}/\text{kg}$)	f_c/B_{ac} (Hz/ μT)
H^+	95.76	15.24
Mg^{2+}	7.93	1.26
Ca^{2+}	4.81	<u>0.77</u>
K^+	2.47	0.39

An important characteristic of resonance is the bandwidth response of the system, particularly because it determines the required tolerances of the test system. Initial development of the IPR model used literature data to estimate the bandwidth for any ion resonance to be $\pm 10\%$ of its exact resonance.

The model is based on combination of static and alternating magnetic fields applied to a bio-system.

There were also some critics of the IPR and some critical failures of the IPR alleged. One of them was Adair in 1992. One of the deficits he noted is that the forces containing the ion must be spherically symmetric. In heterogeneous environment of biological systems, such symmetry is not credible and the states that are split by the Zeeman Effect are not split in different ways with larger magnitudes which negates any IPR effect. After this criticism, in 1995, Blackman and Blanchard improved this model of IPR. They predict different magnetic field (MF) interactions with biological systems based on selective relation among four factors: flux density of static MF, frequency and flux density (B_1) of parallel alternating current MF, and charge-to-mass ratio of biological relevant ions [12].

Their research with nerve cells demonstrates that MF can interact with biological systems. The result supports the model of IPR and its ability to predict relative changes in inhibition for each cycle and the intensities when the null effect occurs. The IPR model, which is considered in this article, covers invoke precession of ions depending on the orientation of the MF and is one of the most important subjects in many experimental investigations [11, 13].

The effect of EMF with low frequencies is still much discussed. It has potential to be used in medicine or in other fields for studies of biological cells.

3 EXPERIMENTAL

3.1 Exposure system and used material

Specific experimental measurements are carried out in this study based on the IPR theory. Exposure system consists of an exposure coil a signal generator and an amplifier. The apparatus was designed to assure identical exposure conditions for both sample pairs exposed and

reference samples. Exposed samples were in microtiter plate and reference samples were placed in a box with magnetic shield.

Candida albicans CCM 8186 was chosen for our experiments. The purity of microorganism was secured by Czech collection of microorganisms (CCM), Masaryk University in Brno. *C. albicans* is a diploid fungus that grows as yeast and also as filamentous cells. It is the most common human fungal pathogen causing mucosal and systematic infections [14].

Microorganisms were processed in glucose solution. One plate was placed to the coil, another one to the shielded box, with the same ambient temperature as the exposed sample. After four hours of exposure the whole volume of exposed and reference samples were pipetted to the blood agar. Finally all Petri dishes were placed to isothermal chamber with stable temperature 37,6 °C for 24 hours. After that time, samples were taken out from the isothermal chamber and the numbers of colonies in each plate were evaluated.

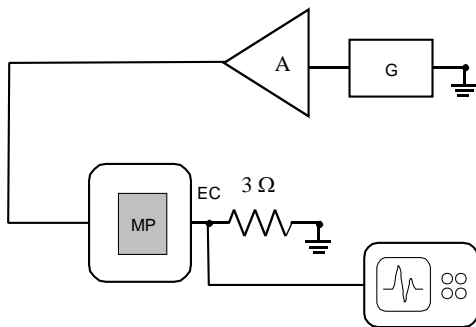

Fig. 1. Exposure system: EC – exposure coil, G – signal generator, A – amplifier; exposed samples in a micro-titer plate (MP), reference samples in a magnetic shield

The exposure coil system was designed to obtain more reliable results and to achieve at most 5% of inhomogeneity of the applied EMF in the volume of exposed samples [11]. Inductance of the whole coil system, that was measured by sensitive LC-meter, was $L = 5.346$ mH. The values of B-field, of sinusoidal current 1 A, were from 2.37 to 2.49 mT which confirming the coil system was designed adequately, [13]

Simulation of homogeneity is presented in Fig. 2. The exposure system was made from three coaxial air coils connected in series. The two outer coils had triangular shape of the longitudinal section to be able to create homogenous EMF and the middle one had the rectangular shape of the longitudinal section to be able to stabilize the EMF in the air-hole of the exposure system. Numerical simulations proved that the desired homogeneity in the exposed area is achieved using the special design of the system. [15]

3.2 Measurement results

The biological responses of specific cells on the LF EMF were experimentally studied using the exposure system described in the previous section. The investigations

and evaluation were based on previous research presented in [11, 13].

Biological subject of research of LF EMF impact was represented by the *Candida albicans* cells. The proliferative responses of *C. albicans* to artificial LF ELF were observed during the experiment. The influence of EMF on the cell growth was then investigated. The growth of *Candida albicans* was secured by the blood agar plate (BAP). BAP contains mammalian blood, usually sheep or horse, with concentration of 5 - 10 %. BAP is differential medium used to isolate fastidious organisms.

Exposition of biological samples was realized by designed system, with exposition time of 4 hours. The reference and exposed samples were incubated during the whole test. Evaluation of experiment was performed immediately after picking the samples from the isothermal chamber. The yeast colonies are visible on Petri dishes as white elevated spots. Count of colonies from exposed sample were compared to reference samples ones, Fig. 3 and Fig. 4.

Table 2. Results of experiments at 1.24 kHz

<i>C. albicans</i>	1	2	3	4
Reference	154	123	64	67
Exposed	108	61	29	46
Exposed/Referenc	0.70	0.50	0.45	0.69

Table 3. Results of experiments at 1.26 kHz

<i>C. albicans</i>	1	2	3
Reference	923	923	128
Exposed	337	304	58
Exposed/Referenc	0.365	0.329	0.453

Frequency and magnetic flux density of alternating current of EMF were chosen according to the IPR theory. As it can be seen in Table 2, 1.24 kHz frequency and 1.6 mT magnetic flux density of alternating current B_{ac} may be considered for resonance frequency of Ca^{2+} ions. Response of biological system, which is observed, corresponds to function of calcium channels that influence cell cycle.

Generated MF B_{ac} was chosen according to the cyclotron resonance value of frequency f_c for ions of Ca^{2+} , with q equal to elementary charge 1.602×10^{-19} C, $m_{Ca} = 6.653 \times 10^{-19}$ kg the calcium ion mass, and $B_{ac} = 1.6$ mT being the magnetic flux density of alternating current in the coil. Calculated cyclotron resonance frequency was $f_c = 1240$ Hz. The ratio of frequency to magnetic flux density corresponds to 0.77 that concur to cyclotron frequency of Ca^{2+} in Tab.1. That is the reason, why it is possible to describe the effect in conformity with the IPR.

The measurement was repeated four times with the same parameters: electromagnetic induction rms value

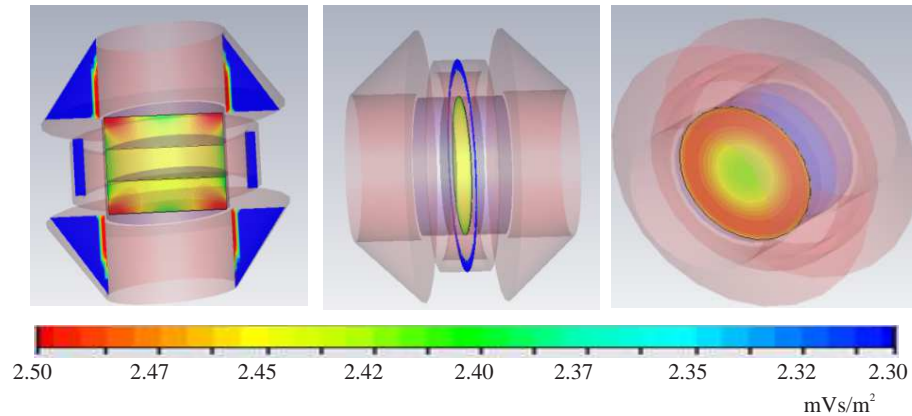

Fig. 2. Model of exposure coil system simulation results of B field, [15]

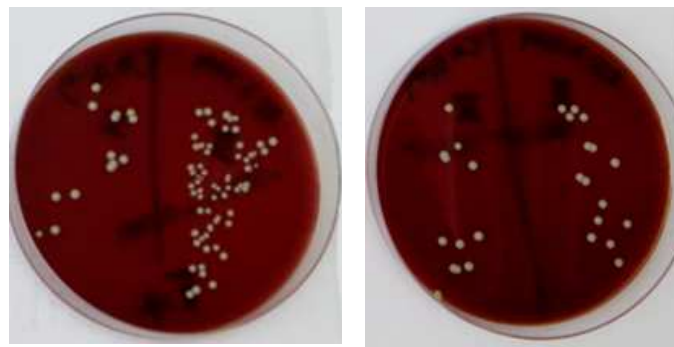

Fig. 3. Results of an experiment (a) – reference samples (64 colonies), (b) – exposed samples (29 colonies)

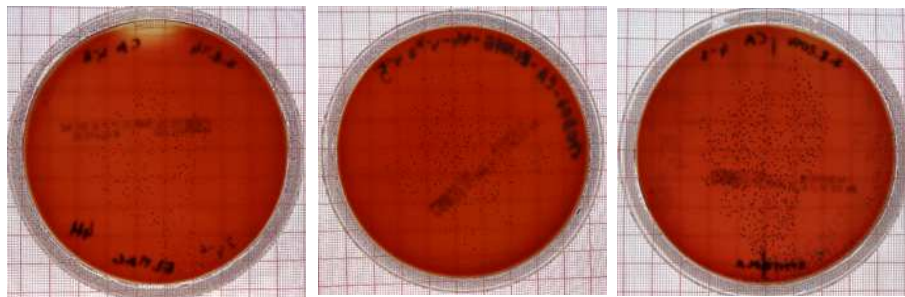

Fig. 4. Results of other experiments: (a) – reference samples (923 colonies), (b) – exposed samples (337 colonies) and (c) – exposed samples (304 colonies)

1.6 mT, frequency 1240 Hz with 1.17 A current. Final samples were processed by a colony counting software OpenCFU. Selected samples were also counted manually to confirm the calculation of OpenCFU. Results of measuring and counting were transformed to the ratio of CFU count of exposed samples to reference samples (Exp/Ref) see Tab. 2. The Exp/Ref ratio varies from 0.45 to 0.7.

In next experiment, Tab. 3, frequency 1.26 kHz was used. To be able to describe the effect for Ca^{2+} channels, according to IPR theory, the magnetic flux density was changed to 1.63 mT. Evaluation is the same as in previous experiment, Fig. 4. Exp/Ref ratio varies from 0.329 to 0.453.

The highest and the lowest ratio of Exp/Ref for *Candida albicans* culture were observed in the first and the

sixth measurement respectively, Fig. 3 and Fig. 4. This difference might be caused by the initial solution concentration and systematic uncertainties. The decreasing effect on *Candida albicans* growth appears in all cases.

6 CONCLUSION

Presented article dealt with non-thermal effects and impact of low frequency electromagnetic field on biological structures and focused on ion channels in cells. Mechanisms of electromagnetic field influences and the theory of ion parametric resonance were briefly described.

We focused especially on the Ion Parametric Resonance (IPR) theory. Experimental measurements were

carried out under various concentrations in order to investigate relevance of the theory. An exposure system was designed, allowing the experimental verification of electromagnetic field exposure on cells of *Candida albicans*. All experiments are in conformity with the IPR theory. The main aim is proving influence on a calcium ion channel in cell membrane. According to parameter of cyclotron resonance for calcium ions, the ratio of frequency and magnetic flux density equals to 0.77. Samples were exposed to LF EMF for 4 hours.

The exposed and reference samples were compared. The Exp/Ref ratio varied from 0.33 to 0.7.

Acknowledgment

This research was supported by the Czech Technical University in Prague grant No. SGS13/194/OHK3/3T/13.

REFERENCES

- [1] Scientific Committee on Emerging and Newly Identified Health Risks (SCENIHR) The opinion of Scientific Committee at the 28th plenary on 19 January 2009.
- [2] CHERRY, N. J.: Evidence that Electromagnetic Radiation is Genotoxic, The implications for the epidemiology of cancer and cardiac, neurological and reproductive effects. 2002.
- [3] ERDAL, N.—GÜRGÜL, S.—CELIK, A: Cytogenetic effects of extremely low frequency magnetic field on Wistar rat bone marrow, *Mutation Research/Genetic Toxicology and Environmental Mutagenesis* (2007), 630.1: 69-77.
- [4] YANG, Y. *et al* : Case-only study of interactions between DNA repair genes (hMLH1, APEX1, MGMT, XRCC1 and XPD) and low-frequency electromagnetic fields in childhood acute leukemia, *Leukemia & lymphoma* (2008), 49.12: 2344-2350.
- [5] CHO, Y. H.—JEON, H. K.—CHUNG, H. W.: Effects of extremely low-frequency electromagnetic fields on delayed chromosomal instability induced by bleomycin in normal human fibroblast cells, *Journal of Toxicology and Environmental Health, Part A* (2007), 70.15-16: 1252-1258.
- [6] FU, Y. *et al* : Long-term exposure to extremely low-frequency magnetic fields impairs spatial recognition memory in mice, *Clinical and Experimental Pharmacology and Physiology* (2008), 35.7: 797-800.
- [7] LIU, T. *et al* : Anxiogenic effect of chronic exposure to extremely low frequency magnetic field in adult rats, *Neuroscience letters* (2008), 434.1: 12-17.
- [8] LIU, T. *et al* : Chronic exposure to low-intensity magnetic field improves acquisition and maintenance of memory, *Neuroreport* (2008), 19.5: 549-552.
- [9] GERARDI, G. *et al* : Effects of electromagnetic fields of low frequency and low intensity on rat metabolism, *Biomagnetic research and technology* (2008), 6.1:3.
- [10] ZHADIN, M. N.—FESENKO, E. E. : . Ionic cyclotron resonance in biomolecules, *Biomedical science* (1990), 1.3: 245-250.
- [11] BARABAS, J.—RADIL, R.: Evidence of *s. cerevisiae* proliferation rate control via exogenous low frequency electromagnetic fields, *Information Technologies in Biomedicine*, Springer Berlin Heidelberg (2012), 295–303.
- [12] BLACKMAN, C. F.—BLANCHARD, J. P.: Experimental determination of hydrogen bandwidth for the ion parametric resonance model, *Bioelectromagnetics* **20** (1999), 5–12.
- [13] BARABAS, J.—RADIL, R.: Investigation of low frequency electromagnetic field influence on cell proliferation process, *ELEKTRO*, 2012. IEEE, 2012.
- [14] SMEEKENS, S. P. *et al* : Nature communications, 4: 1342.
- [15] RADIL, R.—JANOUSEK, L.: Yeast growth influenced by parallel combination of time-varying and static LF EMF, *Communications: scientific letters of the University of Žilina*, **15** No. 2A (2013), 28–32..

Received 17 December 2014

Ivona Malíková was born in Liptovský Mikuláš in 1988. She graduated on Faculty of Electrical Engineering, Department of Electromagnetic and Biomedical Engineering, University of Žilina in 2012. In the present time she is a PhD student at the University of Žilina specialising on effects of low frequency electromagnetic fields.

Ladislav Janoušek was born in Michalovce. He graduated master study at the Department of Power Electrical Systems, Faculty of Electrical Engineering, University of Žilina in 1997. He continued with PhD study at the same department in the field of electric machines and graduated in 2002. He became an associate professor in the field Theory of Electrical Engineering in 2007. Currently he works at the Department of Electromagnetic and Biomedical Engineering, Faculty of Electrical Engineering, University of Žilina. His research activities are focused on electromagnetic methods of non-destructive evaluation and influence of electromagnetic field on living organisms.

Vladyslava Fantova graduated in Biomedical Engineering from Faculty Electrical Engineering, Czech Technical University in Prague in 2010, and now she is a PhD student at the Department of Physics, FEE, CTU. Her main research is focused on cold atmospheric pressure plasma surface decontamination.

Jaroslav Jíra was born in Prague. He graduated his master study at the Department of Power Engineering, Faculty of Electrical Engineering, Czech Technical University in Prague in 1990. He continued with PhD study at the Department of Physics in the field of bacteria inactivation in the brewery industry and graduated in 1994. He became an assistant professor at the Department of Physics in 1996. Currently he works at the Department of Physics, Faculty of Electrical Engineering, Czech Technical University in Prague. His research activities are focused on electrostatic and electromagnetic methods of microorganism inactivation.

Vítězslav Kříha was born in Jilemnice, the Czech Republic, in 1968. He received the MSc degree in electronics from the Faculty of Electronics, Leningrad Electrotechnical University (LETI), Saint Petersburg, Russia, in 1992, the PhD degree in plasma physics from the Faculty of Electrical Engineering, Czech Technical University in Prague, in 2000, and the MD degree in general medicine from the First Faculty of Medicine, Charles University, Prague, in 2003. From 1992 to 1995 he has been a lecturer at the Czech Technical University since 1995. Since 2010, he has been head of the Department of Physics, the Faculty of Electrical Engineering, Czech Technical University in Prague. His research interests include plasma diagnostics, plasma chemical processes and their application for decomposition of volatile pollutants and ozone generation, plasma sterilization and decontamination, and nephrology.