

SMALL–SIGNAL ANALYSIS OF AUTONOMOUS HYBRID DISTRIBUTED GENERATION SYSTEMS IN PRESENCE OF ULTRACAPACITOR AND TIE–LINE OPERATION

Prakash K. Ray* — Soumya R. Mohanty** — Nand Kishor**

This paper presents small-signal analysis of isolated as well as interconnected autonomous hybrid distributed generation system for sudden variation in load demand, wind speed and solar radiation. The hybrid systems comprise of different renewable energy resources such as wind, photovoltaic (PV) fuel cell (FC) and diesel engine generator (DEG) along with the energy storage devices such as flywheel energy storage system (FESS) and battery energy storage system (BESS). Further ultracapacitors (UC) as an alternative energy storage element and interconnection of hybrid systems through tie-line is incorporated into the system for improved performance. A comparative assessment of deviation of frequency profile for different hybrid systems in the presence of different storage system combinations is carried out graphically as well as in terms of the performance index (PI), *ie* integral square error (ISE). Both qualitative and quantitative analysis reflects the improvements of the deviation in frequency profiles in the presence of the ultracapacitors (UC) as compared to other energy storage elements.

Key words: frequency deviation, hybrid system, integral square error, tie-line operation, ultracapacitors

1 INTRODUCTION

Small scale power generation sources like wind, photovoltaic(PV), fuel cells(FC), small hydro etc. are gradually gaining popularities world-wide and replacing conventional power generating technologies in various applications because of the fast depletion of fossil-fuel, air-pollution, high transmission losses, high capital investments, global climatic changes and many more problems. In order to overcome these difficulties and tackle the increasing power demand, an alternative power generation in the form of "distributed generations" has been considered as feasible solution to above related problems. All the renewable energy resources with energy storage devices like battery, ultracapacitors can be integrated to formulate different hybrid energy systems for a reliable power supply. The advantages of hybrid distributed generation concept has been exploited to overcome the limitations in wind and photovoltaic resources since their performance characteristics depend on undesirable changes in wind speed and solar-radiations respectively. In the current de-regulation environment in electricity market, the power sectors need to be restructured and the strategies of the power supply should be reformed [1]. In response to the de-regulation and re-structure in power market, a new business opportunities lead to attract many private sectors to invest money for small scale power generation from economic point of view [2]. In this context, the modern power system engineers are inclined to incorporate a hybrid power generation with energy storage options. These may include different renewable energy sources such as

wind, PV, FC etc. with energy storage units like battery energy storage system (BESS), flywheel energy storage system (FESS), ultra capacitors (UC), etc. The storage systems are meant to supply the peak power demand and harness the abundant available power. However to achieve it successfully effective co-ordination and control is required. Due to the advances in technology and field experiences in wind power generation (WPG), the cost of power generation by wind turbinas has already been reduced and the research is actively motivated for this alternate resources [3]-[5]. Similarly, advancement of technologies in photovoltaic power generation (PVPG) leads to increase in the efficiency and the reduction in cost. Large PVPG system is being operated either as grid connected or isolated system through dc-ac converters [6]-[8].

The hybrid power system with integration of PV with FC offers promising advantages over independent operation [9]. Energy storage plays an important role in hybrid energy system for storing and releasing energy at proper time. The slower response of FC is eliminated by use of ultracapacitors or battery due to its high energy density [10], [11]. Another storage option like flywheel energy storage system (FESS) stores electric energy in terms of the kinetic energy of flywheel. The advantages of FESS are in the form of high power exchange, high stored energy density and high efficiency [12]. Battery energy storage system (BESS) is economical and stores effectively to release energy through power converters during the peak-load demand. Ultracapacitors store electrical energy with high power density as compared to battery. The ultracapacitors have been modeled for effective storage and

* Research Scholar, Department of Electrical Engineering, Motilal Nehru National Institute of Technology Allahabad, India, pkraymnit@gmail.com, ** Department of Electrical Engineering, Motilal Nehru National Institute of Technology Allahabad, India

release of energy [13]. Diesel engine generator (DEG) may be introduced into the hybrid system to meet the deficit in power demand. The hybrid combinations of all the generating sources such as WPG, PVP, FCPG and DEG along with the energy storage system combinations like FESS-BESS and FESS-UC provide an efficient energy control to meet the power balance conditions [14]-[18]. Tie-line bias is a power system control characteristic that determines how much a particular area of an interconnected system should respond to system frequency variation. There are many advantages of interconnection with tie-line control. Under normal operating condition each control area takes care of its own frequency variation. But in case of any abnormal conditions tie-lines manage the power flow in such a way that the frequencies of the control areas remain well within the specified limit.

The work presented in the paper is organized as follows. Section 2 describes the modeling of various energy resources and storage systems in the form of transfer functions. Section 3 describes the configuration of the proposed hybrid systems. This is followed by descriptions on the combination of different energy sources in Section 4. The interconnection of hybrid systems is discussed in Section 5 followed by the simulation results and discussions of both the cases *ie* the isolated and the interconnected hybrid systems in Section 6. Finally the conclusion is given in Section 7.

2 SYSTEM MODELLING

The various renewable sources are integrated for an effective and reliable power supply during different load conditions. However the sources like wind and PV have inherently random characteristics due to different climatic conditions. Both wind speed and solar radiations have complimentary features which may reduce the capacity of the energy storage systems. Hence FC may be integrated with such sources along with the energy storage systems such as BESS, FESS etc. to overcome the above mentioned problems. Prior to the detailed study of the integrated hybrid system, the modeling and characteristics of the different components are carried out and presented in the subsequent sub-sections. In the present work with the consideration of small disturbances, the system nonlinearities have been linearized in order to minimize the complexities in modeling and frequency deviation analysis. As a result in the modeling part, the system nonlinearities have not been taken into account and the systems are simulated in simplified form as linear first order transfer functions [19].

2.1 Wind Power Generation

The generated power of the wind turbine generator depends upon the wind speed V_W . The wind speed is considered to be the algebraic sum of base wind speed (V_{WB}), gust wind speed (V_{WG}), ramp wind speed

(V_{WR}) and noise wind speed (V_{WN}) [20]. Hence speed is given by

$$V_W = V_{WB} + V_{WG} + V_{WR} + V_{WN} \quad (1)$$

The detailed mathematical modeling of these wind speed components are considered from the reference [19].

The mechanical power output of the wind turbine is expressed as

$$P_W = \frac{1}{2} \rho A_r C_p V_W^3 \quad (2)$$

where ρ – is the air density (kg/m^3), A_r – is the swept area of blade (m^2) and C_p – is the power co-efficient which is a function of tip speed ratio (λ) and blade pitch angle (β).

The transfer function of WTGs is given by a simple linear first order lag by neglecting all the non-linearities

$$G_{\text{WTG}_k}(s) = \frac{K_{\text{WTG}}}{1 + sT_{\text{WTG}}} = \frac{\Delta P_{\text{WTG}_k}}{\Delta P_W}, \quad (3)$$

for $k = 1, 2, 3$ and with K_{WTG} – the gain constant and T_{WTG} – the time constant.

2.2 Photovoltaic power generation

A PV system consists of many cells connected in series and parallel to provide the desired voltage and current. The voltage and current relationship is non-linear in nature. The maximum power output of the PV array varies according to solar radiation or load current. Therefore control strategy is required to use solar radiation effectively in order to obtain maximum power. The output power of the PV system can be expressed as

$$P_{\text{PVP}} = \eta S \phi [1 - 0.005(T_a + 25)] \quad (4)$$

where are: η – the conversion efficiency of the PV array, S – the measured area of PV array (m^2), ϕ – the Solar radiation (kW/m^2) and T_a – the ambient temperature (Celsius degree).

The transfer function of PV can be given by a simple linear first order lag

$$G_{\text{PV}}(s) = \frac{K_{\text{PV}}}{1 + sT_{\text{PV}}} = \frac{\Delta P_{\text{PVP}}}{\Delta \phi} \quad (5)$$

with K_{PV} – the gain constant and T_{PV} – the time constant.

2.3 Fuel-cell power generation

Fuel cells are static energy conversion device which converts the chemical energy of fuel (hydrogen) directly into electrical energy. They are considered to be an important resource in hybrid distributed power system due to the advantages like high efficiency, low pollution, flexible modular structure etc. Neglecting all the non-linearities, transfer function of FC can be given by a simple linear first order lag

$$G_{\text{FC}_k}(s) = \frac{K_{\text{FC}}}{1 + sT_{\text{FC}}} = \frac{\Delta P_{\text{FC}_k}}{\Delta P_{\text{FCPG}}}, \quad (6)$$

for $k = 1, 2$ and with K_{FC} – the gain constant and T_{FC} – the time constant.

2.4 Diesel engine power generation

Standby DEG work autonomously to supply the deficit power to the hybrid system to meet the power-load demand balance condition. The transfer function of DEG can be given by a simple linear first order lag

$$G_{\text{DEG}}(s) = \frac{K_{\text{DEG}}}{1 + sT_{\text{DEG}}} = \frac{\Delta P_{\text{DEG}}}{\Delta f} \quad (7)$$

with K_{DEG} – the gain constant and T_{DEG} – the time constant.

2.5 Aqua-electrolyzer for production of hydrogen

A part of P_{WPG} or/and P_{PV} is to be utilized by AE for the production of hydrogen to be used in fuel-cell for generation of power. The transfer function can be expressed as first-order lag

$$G_{\text{AE}}(s) = \frac{K_{\text{AE}}}{1 + sT_{\text{AE}}} \quad (8)$$

with K_{AE} – the gain constant and T_{AE} – the time constant.

2.6 FESS/BESS as energy storage system

Flywheel Energy Storage System (FESS) or Electromechanical Battery is a kinetic energy storage device which behaves just as batteries. The device is designed to store energy mechanically in a rotating flywheel rotor so it can be retrieved later as an electrical output. The advantages of flywheel systems versus batteries are higher power density, insensitivity to environmental conditions, no hazardous chemicals and ease of checking the charge. FESS stores electric energy by the help of the kinetic energy stored in the rotating flywheel given by

$$E = \frac{1}{2}I\omega^2 \quad (9)$$

where E – is the energy stored in the flywheel (Nm), I – is the flywheel moment of inertia (Nm sec²) and ω – is the rotational velocity (rad/sec).

With the rapid advances in power electronics technology, the Battery Energy Storage System (BESS) has recently been shown to have the capability to quickly control both its active and reactive power output at switching frequency well above the kHz range. While the main applications of such a device are usually for load leveling, harmonic cancellation and voltage control, and once installed, it could also be utilized to provide additional damping to power system swings to improve both transient and dynamic stability. The BESS comprises of a DC battery bank connected to the AC power system through transformers and a power electronic converter which convert the DC power to AC power during energy discharge and convert the AC power to DC power during charging. The conversion is achieved by the fast control of the

power switching modules associated with the converter. With proper control strategy, the BESS can provide rapid change of active and reactive power both in positive and negative value. The ability to quickly change the operation of the BESS from being a load to being a generator means the BESS can be modulated to oppose any frequency oscillation in the power system. The transfer functions of the storage systems BESS and FESS can be represented as first order lag [19]

$$G_{\text{FESS}}(s) = \frac{K_{\text{FESS}}}{1 + sT_{\text{FESS}}} = \frac{\Delta P_{\text{FESS}}}{\Delta f} \quad (10)$$

$$G_{\text{be}}(s) = \frac{K_{\text{BESS}}}{1 + sT_{\text{BESS}}} = \frac{\Delta P_{\text{BESS}}}{\Delta f} \quad (11)$$

with K_{FESS} , K_{BESS} – the gain constants and T_{FESS} , T_{BESS} – the time constants.

2.7 Ultracapacitors as Alternative energy storage device

Ultracapacitors are electrochemical type capacitors which offer large capacitances in the order of thousands of farads at a low voltage rating of about 2.5V [21]-[23] and are used to store electrical energy during surplus generation and deliver high power within a short duration of time during the peak-load demand [24]-[27]. The energy density of an ultracapacitor is 100 times larger than the conventional electrolytic capacitor and their power density is 10 times larger than the lead-acid battery. Ultracapacitors possess a number of attractive properties like fast charge-discharge capability, longer life, no-maintenance and environmental friendliness. The effective specific energy for a prescribed load can be satisfied by using various UC bank configurations. In practical applications, the required amount of terminal voltage and energy or the capacitance of UC storage system can be achieved using multiple UCs in series and parallel. The terminal voltage determines the number of capacitors which must be connected in series to form a bank and the total capacitance determines the number of capacitors which must be connected in parallel in the bank. The UC units can be arranged to build a UC bank, which is capable of providing the short-term peak load demand. The amount of energy drawn from UC bank is directly proportional to the capacitance and the change in the terminal voltage, expressed as

$$E_{\text{UC}} = \frac{1}{2}C(V_i^2 - V_f^2) \quad (12)$$

where E_{UC} – is the amount of energy released or stored by the capacitor bank (Watt sec), V_i – is the initial voltage of the UC bank before discharging (V), and V_f – is the final voltage of the UC bank after discharging (V).

Similarly the transfer function of the ultracapacitor can be represented as a first order lag

$$G_{\text{UC}}(s) = \frac{K_{\text{UC}}}{1 + sT_{\text{UC}}} = \frac{\Delta P_{\text{UC}}}{\Delta f} \quad (13)$$

with K_{UC} – the gain constant and T_{UC} – the time constant of the ultracapacitor bank.

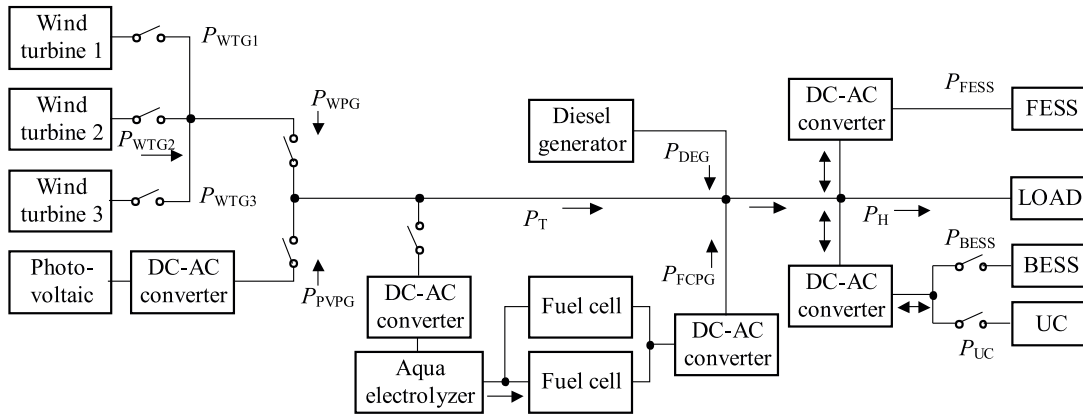

Fig. 1. Configuration of hybrid energy resources/storage systems

3 CONFIGURATION OF ENERGY RESOURCES / STORAGE SYSTEMS

The various energy resources/storage systems as explained in previous Section-2 may be integrated to form hybrid system as shown in Fig. 1. In this study, power is generated through three WTG, PV, two FC and DG, the aqua-electrolyzer as shown converts a part of generated power from wind or/and PV for hydrogen production to be used by fuel cells. The different combinations of energy storage system can be facilitated for reliable power supply to the connected load. The storage systems along with AE, PV and FC are to be connected through suitable converters as shown, but have not been considered here in order to avoid the complexities in the modeling. The energy storage systems BESS, FESS and UC store energy during the surplus generation and release efficiently during the peak-load demand. The DEG is to be taken as the standby generator which starts automatically to make up the deficit power demand.

The total power generation by the hybrid system is given as

$$P_H = P_T + P_{DEG} + P_{FCPG} \pm P_{FESS} \pm (P_{BESS} \text{ or } P_{UC}) \quad (14)$$

where

$$P_T = P_{WPG} - P_{AE} = \left(\sum_{i=1}^3 P_{WTG_i} \text{ or/and } P_{PV} \right) - P_{AE} = K_n P_{WTG} \quad (15)$$

here, P_T – is the net power of WTGs and PVs to the system, and

$$K_n = \frac{P_T}{P_{WPG} \text{ or/and } P_{PVPG}} \quad (16)$$

. The power-frequency balance is maintained by a proper control of different power generation by the components. The power balance is achieved by the equation

$$\Delta P_e = P_H - P_L \quad (17)$$

where P_H – is the total power generation and P_L – is the total power demand.

The change in the frequency profile (Δf) is expressed by the equation

$$\Delta f = \frac{\Delta P_e}{K_{sys}} \quad (18)$$

where K_{sys} is the system frequency characteristic constant of the hybrid system. The transfer function for the system variation to per unit deviation in power is expressed by

$$G_{sys} = \frac{\Delta f}{\Delta P_e} = \frac{1}{K_{sys}(1 + sT_{sys})} = \frac{1}{D + Ms} \quad (19)$$

where M and D are respectively the equivalent inertia constant and damping constant of the hybrid system [28].

4 INTEGRATION TOPOLOGIES FOR ISOLATED HYBRID SYSTEMS

In distributed generation, the different energy resources need to be connected to form hybrid system for power security. This section describes six topologies along with energy storage systems. Every hybrid system consists of power generating sources such as WTGs, PV, FC and DEG with the energy storage system combinations; FESS-BESS or FESS-UC. The components of the hybrid systems are properly operated with the help of power converters to meet the power balance condition. All the topologies are simulated and analyzed to address the variation in the deviation of frequency profile. The isolated hybrid systems 1, 2 & 3 [19] and new isolated hybrid systems 4, 5 & 6 with all the energy resources WTG, PV and FC are being simultaneously considered for the analysis of the frequency deviation. The integration topologies for hybrid system are described subsequently.

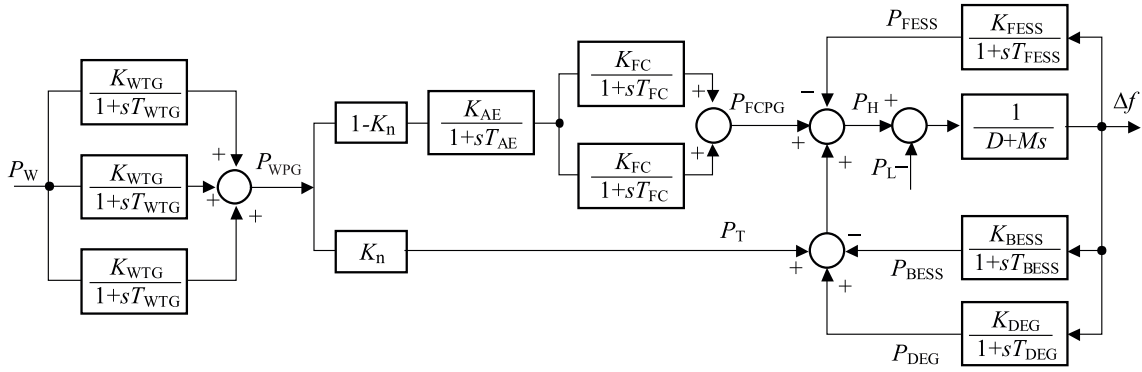

Fig. 2. Block diagram for the hybrid system 1

4.1 Hybrid system 1

The block diagram of the hybrid system 1 is shown in Fig. 2. This case considers three WTGs connected together to generate wind power P_{WPG} in the system. A portion of total power, *ie* $(1 - K_n)P_{WPG}$ is utilized in the aqua-electrolyzer to produce hydrogen as a fuel for two FCs. The FCs generate DC power which is converted to AC power through DC-AC converter, is combined with DEG output P_{DEG} and $P_T (= K_n P_{WPG})$ represent the average power supply to the connected loads. The surplus (insufficient) power of the studied hybrid system is conveniently stored in (released from) energy storage elements with combinations of FESS-BESS or FESS-UC through associated power converters. The resultant power generation can be expressed as

$$P_H = P_{WPG} + P_{DEG} + P_{FCPG} - P_{AE} \pm P_{FESS} \pm (P_{BESS} \text{ or } P_{UC}) \quad (20)$$

4.2 Hybrid system 2

This case assumes the power generation P_{PVPG} from PV system, with three WTGs are disconnected in the above hybrid system. A part of P_{PVPG} , *ie* $(1 - K_n)P_{PVPG}$ is delivered to the AE to produce required hydrogen for a single FC. The FC generates DC power which

is converted into AC power through a DC-AC power converter. The powers P_{FCPG} , P_{DEG} and $P_T (= K_n P_{PVPG})$ are added and taken together to meet the required connected load power. The surplus (insufficient) power of the studied hybrid system is stored in (released from) the energy storage combinations as described earlier. The resultant power generation can be expressed as

$$P_H = P_{PVPG} + P_{DEG} + P_{FCPG} - P_{AE} \pm P_{FESS} \pm (P_{BESS} \text{ or } P_{UC}) \quad (21)$$

4.3 Hybrid system 3

In order to consider this topology, it is assumed that all three WTGs remain connected to the system while AE, PV and BESS are removed from the system. The power generated from three WTGs (P_{WPG}) is combined with P_{DEG} to supply required power demand of the connected load. The surplus (insufficient) power of the studied hybrid system is stored in (released from) FESS through power converters. The resultant power absorbed by the connected load can be expressed as

$$P_H = \sum_{i=1}^3 P_{WTG_i} + P_{DEG} \pm (P_{FESS} \text{ or } P_{UC}) \quad (22)$$

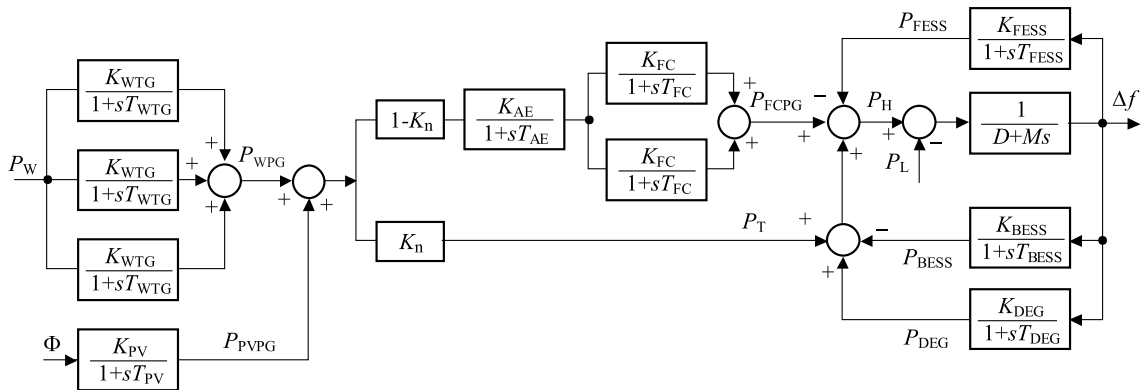

Fig. 3. Block diagram for the hybrid systems 4, 5 & 6

4.4 Hybrid systems 4, 5 & 6

The block diagram of this hybrid topology is shown in Fig. 3. This case considers the combination of WTGs and PV to the system at different instant of times thus leading to three different sub-topologies 4, 5 & 6. The PV, AE and FC remain connected in all the three sub-topologies. The total power generation by wind, *ie* P_{WPG} , and by PV system, *ie* P_{PVPG} is combined. A part of this combined power $(1 - K_n)(P_{WPG} + P_{PVPG})$ is supplied to AE to produce hydrogen for FC. As in this case, the power generation is more due to the presence of all the energy resources, the factor K_n is taken as 0.8. The resultant power generation of this case can be expressed as

$$P_H = P_{WPG} + P_{PVPG} + P_{DEG} + P_{FCPG} - P_{AE} \pm P_{FESS} \pm (P_{BESS} \text{ or } P_{UC}). \quad (23)$$

5 INTERCONNECTION OF HYBRID SYSTEMS WITH TIE-LINE

Reliable and quality power supply to the connected load may be achieved by the interconnection of neighboring isolated hybrid systems through tie-line. Each isolated hybrid system is assumed as control area. Tie-line bias is a power system control characteristic that determines how much a particular area of an interconnected system should respond to system frequency variation. In

addition to that, tie-line is used to exchange energy between control areas to provide inter-area support in case of any abnormal condition. If there is a mismatch between the power generation and load demand, the deviation in frequency for a particular area occurs. Each interconnected hybrid system with two-area interconnection is represented as shown in Fig. 4.

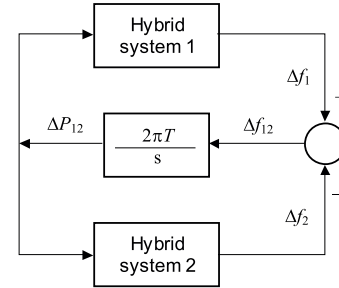

Fig. 4. Modelling of tie-line

Expressing the tie-line power deviation (ΔP_{12}) in terms of deviation in frequency (Δf) is represented as

$$\Delta P_{12} = 2\pi T \left(\int \Delta f_1 dt - \int \Delta f_2 dt \right) \quad (24)$$

Taking the Laplace Transform we have

$$G_{TL}(s) = \frac{\Delta P_{12}(s)}{\Delta f(s)} = \frac{2\pi T}{s} \quad (25)$$

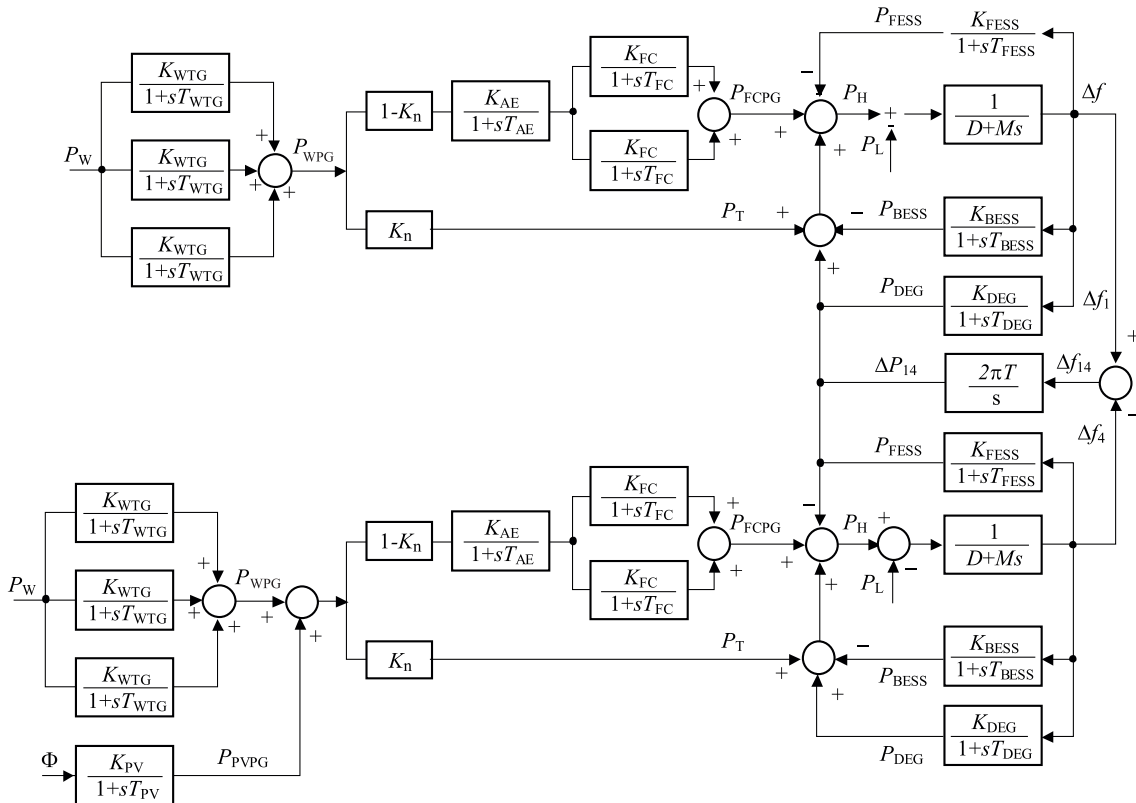

Fig. 5. Block diagram for the interconnection configuration 3

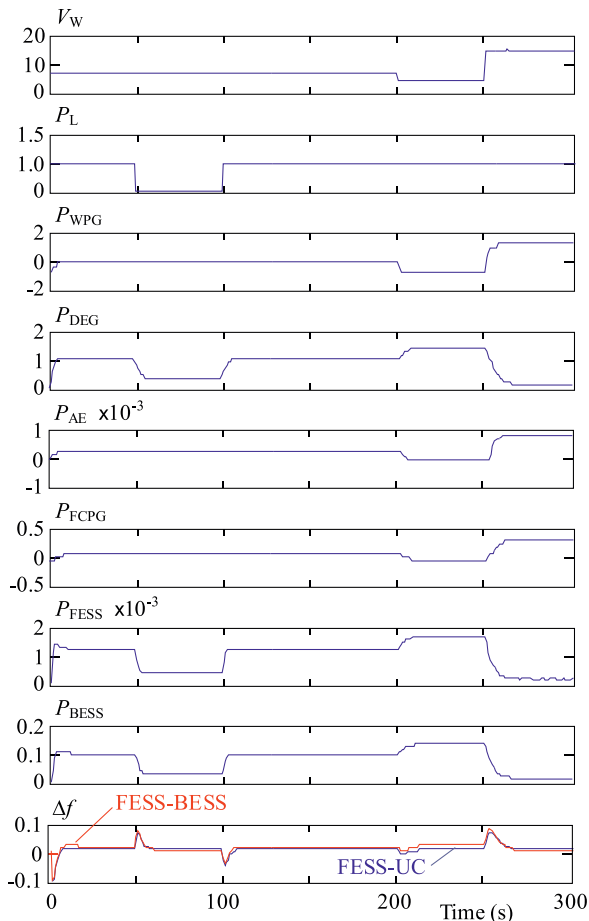

Fig. 6. Time-domain simulation of isolated hybrid system 1

where T – is the synchronizing coefficient of tie-line.

In this paper five interconnected hybrid systems are considered for the simulation study. Each topology is obtained by combination of isolated hybrid systems described in the Section 4. The isolated cases operate properly to meet their individual power demand under normal operating conditions. But in case of any abnormality the imbalance in power-load demand leads to frequency variations. This problem is taken care by the tie-line which

transfers the required power to the individual systems to make the balance between power generation and load demand to improve the frequency deviation. Tie-line regulates the power through the integral control block as shown in Fig. 4. The descriptions of the proposed interconnected systems with tie-line are presented in the subsequent section. The two-area interconnection of hybrid system 1 and hybrid system 4 with its basic building blocks is illustrated in Fig. 5. Although other combinations of two-area interconnection are not shown here, their quantitative analysis is performed and discussed in simulation results and analysis section.

6 SIMULATION RESULTS AND ANALYSIS

In this section the isolated hybrid systems comprising of different combinations of the generating and storage system combinations are simulated and analyzed for various operating conditions and disturbances. The hybrid system with combination of energy storage elements like FESS-BESS and FESS-UC is simulated for the analysis to understand the frequency deviation. The parameters of the elements in the hybrid systems are given in Table-1A in Appendix. All quantities in the plots of this section are in per unit (pu) values except that V_W is in m/s. In the studied cases, V_W is set to be 7.5 m/s from the time interval 0 to 200 secs, suddenly decreased to 4.5 m/s from 200 secs to 250 secs and then suddenly increased to 15 m/s from the time interval 250 secs to 300 secs. The selected values of the wind speed, *ie* 7.5 m/s, 4.5 m/s and 15 m/s and the parameters of each element in the hybrid system are taken from the paper Dong Lee *et al.*, [19]. Sudden decrease and increase in wind speed and load are applied to all the hybrid systems in order to study the frequency deviations. The total power absorbed by the connected loads in the the different hybrid systems is assumed to be 1.0 pu under normal operating condition. In order to simulate the hybrid systems, all the generating and storage systems are assumed to be linear first order system to avoid the system complexities [19]. As a matter of fact, the computational burden is reduced to a greater extent.

Table 1. Quantitative analysis for isolated hybrid system frequency deviation

Topology	Energy resources	Energy storage	ISE(pu) of system combination frequency deviation
HS 1	3-WTG+1-AE+2	FESS+BESS	0.0231
	-FC+ 1-DEG	FESS+UC	0.0185
HS 2	1-PV+1-AE+1	FESS+BESS	0.0427
	-FC+1-DEG	FESS+UC	0.0341
HS 3	3-WTG	FESS+BESS	0.0009
	+1-DEG	FESS+UC	0.0007
HS 4	1-WTG+1-AE+2	FESS+BESS	0.0205
	-FC+1-PV+1-DEG	FESS+UC	0.01910
HS 5	2-WTG+1-AE+2	FESS+BESS	0.1779
	-FC+1-PV+1-DEG	FESS+UC	0.0168
HS 6	3-WTG+1-AE+2	FESS+BESS	0.0111
	-FC+1-PV+1-DEG	FESS+UC	0.0106

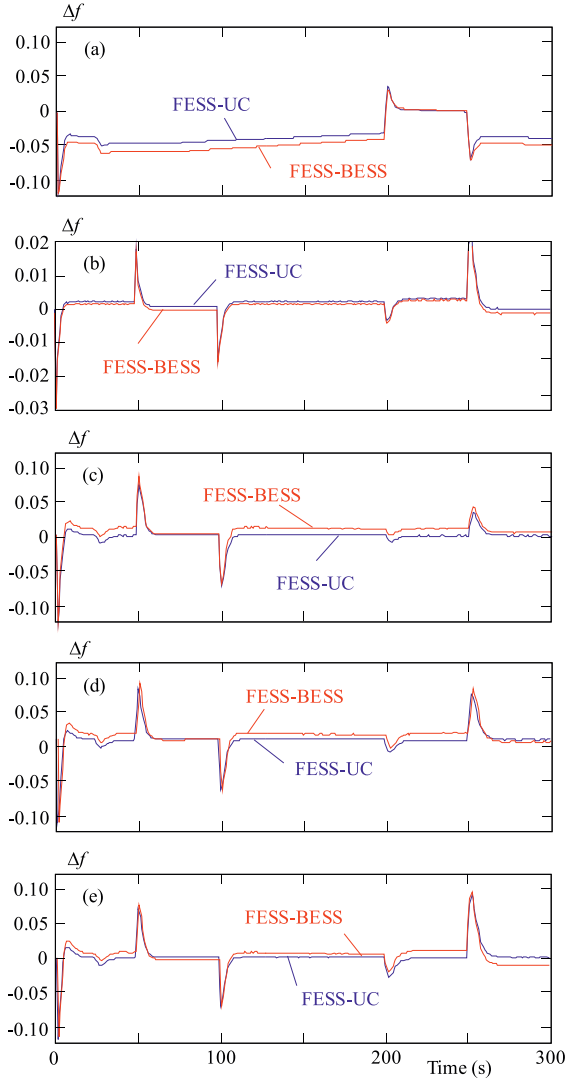

Fig. 7. Frequency deviations of isolated hybrid systems

The integral square error (ISE) is considered as performance index (PI) to quantify the result analysis which is given as

$$ISE = \int \Delta f^2(t) dt \quad (26)$$

where $\Delta f^2(t)$ – is the square of the frequency deviation.

6.1 Time-domain simulation of isolated hybrid systems

The time-domain simulations of different isolated hybrid systems are carried out to visualize the deviation in system frequency profile with different generating systems with the storage system combinations such as FESS-BESS or FESS-UC under different load disturbance conditions. The time-domain simulations of isolated hybrid system 1 for P_{WPG} , P_{DEG} , P_{AE} , P_{FCPG} , P_{FESS} , P_{BESS} along with the comparison of deviation in frequency for the above mentioned storage system combinations is shown in Fig. 6.

Sudden rise and sudden fall in the load (P_L) and random variation in wind speed (V_W) are applied to all the studied hybrid systems to know their behavior and performance. Comparisons of deviation in frequency for other isolated hybrid systems are shown in Fig. 7. The simulation results reflect the improvement in the deviations in the frequency profile with the incorporation of the ultracapacitors (UC). It is suggested that the use of UC, as storage element, results to have either equal or lower magnitude of frequency deviation. Apart from the graphical representation, the quantitative analysis of deviation in frequency calculated in terms of PI, *ie* ISE for both the combinations of storage systems is presented in Table 1. It is observed that use of FESS-UC outperforms with that of FESS-BESS.

6.2 Time-domain simulation results of interconnected hybrid systems

In this sub-section, the frequency deviation of interconnected systems with above discussed topologies of hybrid system is presented. The variation in frequency deviation is analyzed as with and without tie-line operation of the system. It is assumed to have interconnection of HS1 with other topologies of HS. The individual HS is considered to have either FESS-BESS or FESS-UC combination of energy storage elements. The time-domain simulation for interconnection1 with HS1 and HS2 before and after the tie-line operation is shown in Fig. 8.

Table 2. Quantitative analysis of frequency deviation for each hybrid system in tie-line operation

Interconnection configuration	Frequency deviation	ISE(<i>pu</i>) of frequency deviation	
		FESS+BESS	FESS+UC
1	Δf_1	0.0180	0.0129
	Δf_2	0.0361	0.0214
2	Δf_1	0.0160	0.0113
	Δf_3	0.0007	0.0002
3	Δf_1	0.0190	0.0122
	Δf_4	0.0200	0.0188
4	Δf_1	0.0120	0.0117
	Δf_5	0.0116	0.0109
5	Δf_1	0.0160	0.0111
	Δf_6	0.0100	0.0070

Table 3. Quantitative analysis for tie-line frequency deviation, Δf_{TL}

Interconnection configuration	Control area 1	Control area 2	ISE(<i>pu</i>) of frequency deviation	
			FESS+BESS	FESS+UC
1	HS 1	HS 2	0.0096	0.0006
2	HS 1	HS 3	0.0116	0.0102
3	HS 1	HS 4	0.0005	0.0003
4	HS 1	HS 5	0.0021	0.0008
5	HS 1	HS 6	0.0054	0.0038

The frequency deviation for each hybrid system with tie-line and isolated hybrid system for the energy storage combinations; FESS-BESS and FESS-UC is presented in Fig. 8a and Fig. 8b respectively.

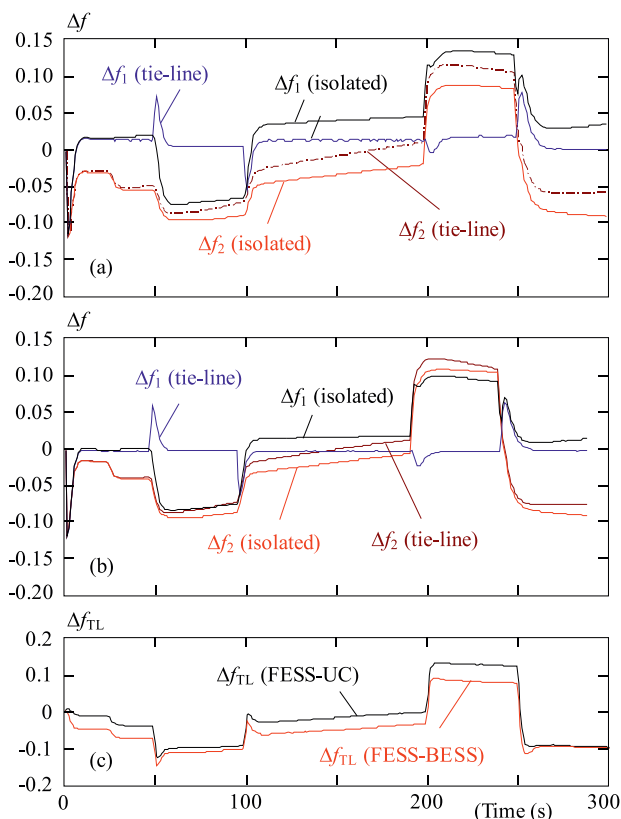
**Fig. 8.** Frequency deviations of isolated hybrid systems

It is observed that tie-line operation of HS results to comparatively reduce the frequency deviation than isolated operation. Further, the frequency deviation profiles Δf_1 and Δf_2 in the hybrid systems with tie-line operation reflects remarkable improvement on use of FESS-UC energy storage combination. Similarly, the reduction in frequency deviation in tie-line is observed as shown in Fig. 8c. Due to space limitations in paper, the time-domain analyses for other interconnection configurations have not been presented. The quantitative analysis of frequency deviation in terms of ISE for various interconnection configurations is given in Table 2 and 3. The improvement in the frequency deviation with use of UC as energy storage element is reflected from these Tables.

7 CONCLUSIONS

The work presented in this paper has considered the study of frequency deviation in isolated hybrid distributed generation systems and exploited the concept of interconnection by tie-line with different combination of energy storage elements. The deviations in frequency profile for isolated hybrid system as well as interconnected hybrid systems were studied, both qualitatively and quantitatively. A comparative assessment of frequency deviations with FESS-BESS and FESS-UC were presented. A significant improvement in the frequency deviation was observed in both isolated hybrid systems and with tie-line operation with use of energy storage combination in the presence of ultracapacitors as comparison to other storage elements.

APPENDIX

Parameters of the studied hybrid systems

Energy source / Storage system	Gain constant K	Time constant T (s)
WTG	1	1.5
AE	0.002	0.5
FC	0.01	4.0
PV	1	1.8
FESS	-0.01	0.1
BESS	-0.003	0.1
UC	-0.7	0.9
DEG	0.003	2.0

$K_n = 0.8$ for all the hybrid system, $M = 0.4$,
 $D = 0.03$ and for the tie-lines: $2\pi T = 0.0754$ pu

Abbreviations or subscripts

<i>AE</i>	– Quantities of aqua-electrolyzer
<i>DEG</i>	– Quantities of diesel-engine generator
<i>HS</i>	– Hybrid system
<i>IC</i>	– Interconnection configuration
<i>WTG</i>	– Quantities of wind-turbine generator
<i>FC</i>	– Quantities of fuel-cells
<i>PV</i>	– Quantities of Photovoltaic
<i>WPG</i>	– Wind power generation
<i>PVPG</i>	– Photovoltaic power generation
<i>FCPG</i>	– Fuel cell power generation
<i>FESS</i>	– Quantities of flywheel energy storage system
<i>BEES</i>	– Quantities of battery energy storage system

UC – Quantities of ultracapacitors
PG/ESS – Power generation/energy storage system
TL – Quantities of Tie-line
PI – Performance index
ISE – Integral square error

REFERENCES

- [1] ILIC, M.—GALIANA, F.—FINK, L.: Power System Restructuring, Kluwer Academic Publishers, MA, 1998.
- [2] KOEPEL, G.: Distributed generation- literature review and outline of the Swiss situation, Swiss Federal Institute of Technology, Zurich, 2003.
- [3] WANG, P.—BILLINTON, R.: Reliability benefit analysis of adding WTG to a distribution system, *IEEE Trans. Energy Convers* **16** No. 2 (2001), 134–139.
- [4] KODAMA, N.—MATSUZAKA, N.—INOMATA, N.: The power variation control of a wind generator by using probabilistic optimal control, *Trans. Inst. Elect. Eng. Japan* **121** No. 1 (2001), 22–30.
- [5] ANDERSON, P. M.—FOUAD, A. A.: Power System Control and Stability, Ames, IA: Iowa State Univ. Press, 1977.
- [6] FYFE, W. S.—POWELL, M. A.—HART, B. R.—RATANASTHIEN, B.: A global crisis: Energy in the future, *Nonrenewable Resources* **2** (1993), 187–195.
- [7] SHIMIZU, T.—HIRAKATA, M.—KAMEZAWA, T.—WATANABE, H.: Generation control circuit for photovoltaic modules, *IEEE Trans. Power Elect.* **16** No. 3 (2001), 293–300.
- [8] MATSUO, H.—KUROKAWA, F.: Novel solar cell power supply system using bidirectional dc-dc converter, *Proc IEEE Power Electron Spec. Conf. (PESC)*, Cambridge, MA, 1982, pp. 14–19.
- [9] KYOUNGSOOR. Rahman—S.: Two loop controller for maximizing performance of a grid-connected, photovoltaic fuel cell hybrid power plant, *IEEE Trans. Energy Convers* **13** No. 3 (1998), 276–281.
- [10] REDDY, K. N.—AGARWAL, V.: Utility interactive hybrid distributed generation scheme with compensation feature, *IEEE Trans. Energy Convers.* **22** No. 3 (2007), 666–673.
- [11] GAO, W.: Performance comparison of a fuel cell-battery hybrid power train and a fuel cell-ultra capacitor hybrid power train, *IEEE Trans. Veh. Technol.* **54** No. 3 (2005), 846–855.
- [12] WEISSBACH, R. S.—KARADY, G. G.—FARMER, R. G.: Dynamic voltage compensation on distribution feeders using fly-wheel energy storage, *IEEE Trans. Power Del.* **14** No. 2 (1999), 465–471.
- [13] ELGERDO, I.: Electric Energy Systems Theory-An Introduction, second edition, TMH Publication, New York, 1998.
- [14] SENJYU, T.—NAKAJI, T.—UEZATO, K.—FUNABASHI, T.: A hybrid power system using alternative energy facilities in isolated island, *IEEE Trans. Energy Convers.* **20** No. 2 (2005), 406–414.
- [15] VALENCIAGA, F.—PULESTON, P. F.—BATTAIOTTO, P. E.: Power control of a solar/wind generation system without wind measurement: A passivity/ sliding mode approach, *IEEE Trans. Energy Convers.* **18** No. 4 (2003), 501–507.
- [16] RAJASHEKARA, K.: Hybrid fuel-cell strategies for clean power generation, *IEEE Trans. Ind. Appl.* **41** No. 3 (2005), 682–689.
- [17] VALENCIAGA, F.—PULESTON, P. F.: Supervisor control for a stand-alone hybrid generation system using wind and photovoltaic energy, *IEEE Trans. Energy Convers.* **20** No. 2 (2005), 398–405.
- [18] MULJADI, E.—MCKENNA, H. E.: Power quality issues in a hybrid power system, *IEEE Trans. Ind. Appl.* **38** No. 3 (2002), 803–809.
- [19] LEE, D. J.—WANG, L.: Analysis of a novel autonomous marine hybrid power generation/energy storage system with a high-voltage direct current link, *Journal of Power Sources* **185** No. 2 (Dec. 2008), 1284–1292.
- [20] ANDERSON, P. M.—BOSE, A.: Stability simulation of wind turbine system, *IEEE Trans. Power App. Syst.* **102** No. 12 (1983), 3791–3795.
- [21] CONWAY, B. E.: Electrochemical super capacitors scientific fundamentals and technological applications, New York Kluwer Academic / Plenum Press, 1999.
- [22] BURKEA.: Ultra capacitors: why, how, and where is the technology, *Journal of Power Sources, ELSEVIER SCIENCE* **91** (2000), 37–50.
- [23] SPYKERR, L.—NELMSR, M.: Analysis of Double-Layer Capacitors Supplying Constant Power Load, *IEEE Trans. on Aero. and Elect. Syst.* **36** No. 4, 1439–1443.
- [24] RAJKARUNAR, M. A. S.: Small-Signal Transfer Functions Of the classical Boost converter Supplied by Ultracapacitors Banks, *IEEE conf. on Ind. Elect. and Appl.* (2007), 692–697.
- [25] CORLEYM.—LOCKERJ.—DUTTONS.—SPEER.: Ultracapacitors-based ride through system for adjustable speed drives, *IEEE Power conf.* (1999).
- [26] LAIJ, S.—LEVYS.—ROSEM, F.: High energy density double-layer capacitors for energy Storage applications, *IEEE Aero. and Elect. Syst. Mag.* **7** (1992), 14–19.
- [27] DURAN-GOMEZJ. L.—FNJETIP, N.—JOUANNEA. VON.: An approach to achieve ride-through of an adjustable speed drive with fly back converter modules powered by super capacitors, *IEEE Trans. on Ind. appl.* **38** (2002), 514–522.
- [28] SENJYUT.—NAKAJIT.—UEZATOK.—FUNABASHIT.: A hybrid power system using alternative energy facilities in isolated island, *IEEE Trans. Energy Convers.* **20** No. 2 (2005), 406–414.

Received 22 September 2009

Prakash K. Ray is a research Scholar in the Department of Electrical Engineering, Motilal Nehru National Institute of Technology, Allahabad, India. His research area includes distributed generations, renewable energy resources and power quality.

Soumya R. Mohanty received the PhD degree from Indian Institute of Technology (IIT), Kharagpur, India. Currently he is with the Department of Electrical Engineering, Motilal Nehru National Institute of Technology, Allahabad, India. His research area includes distributed generations, digital signal processing applications in power system relaying and power quality.

Nand Kishor received the PhD degree from Indian Institute of Technology (IIT), Roorkee, India. Currently he is with the Department of Electrical Engineering, Motilal Nehru National Institute of Technology, Allahabad, India. His research area includes Artificial intelligence (AI) in power system and distributed generations.